

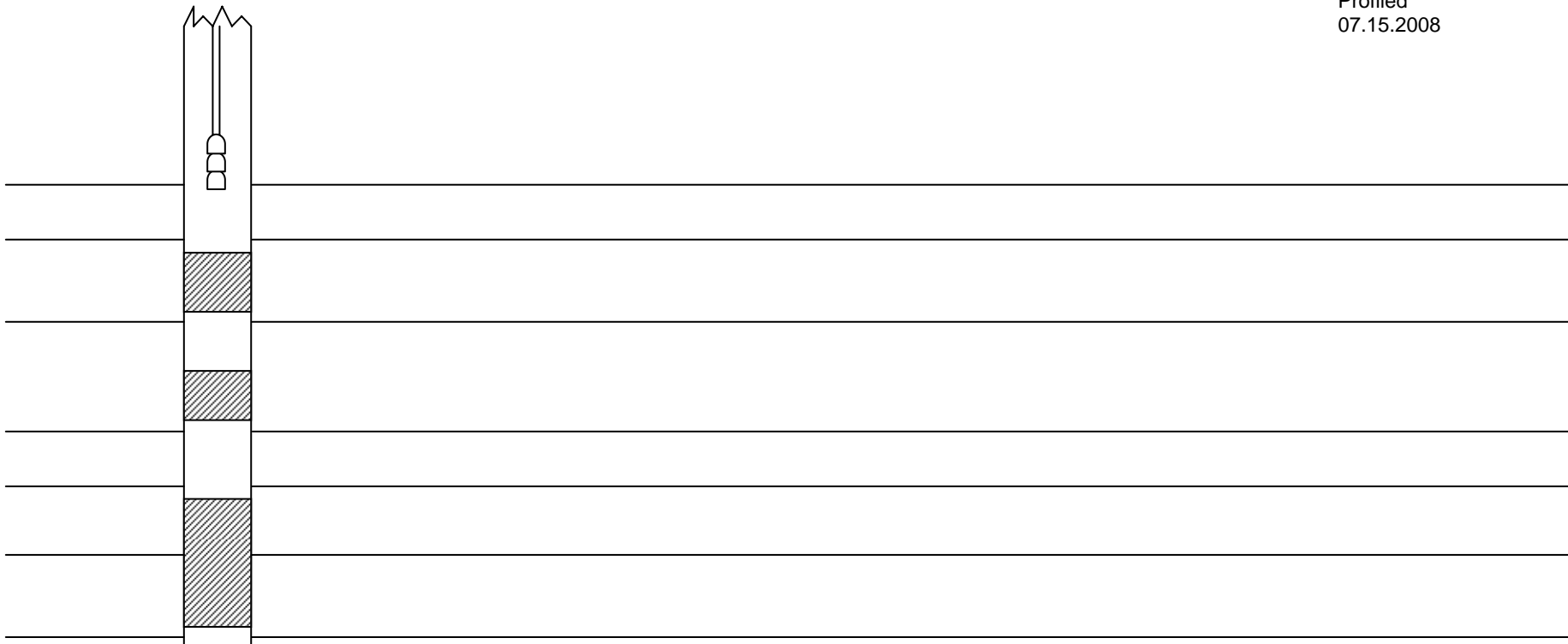

50 Tiburon Street Suite 7
San Rafael , CA 94901
Toll Free.866.298.8701
Phone.415.453.2501
Fax.415.453.2509

Final Report: Dynamic Flow Profile and Water Quality Analysis For SAMPLE WELL

Profiled
07.15.2008



Contents

<u>Dynamic Flow Contribution By Depth and Screen Intervals (GPM)</u>	3
<u>Dynamic Flow Contribution By Depth and Screen Intervals (Percent of Total)</u>	4
<u>Dynamic Flow Velocity By Dye Injection Depth</u>	5
<u>Dynamic Flow Contribution By Screen Intervals (Bar Graph)</u>	6
<u>Mass Balance Analysis By Depth and Screen Intervals (Arsenic)</u>	7
<u>Mass Balance Analysis By Depth and Screen Intervals (Iron)</u>	8
<u>Mass Balance Analysis By Depth and Screen Intervals (Copper)</u>	9
<u>Well Information</u>	10

Dynamic Flow Contribution By Depth and Screen Intervals

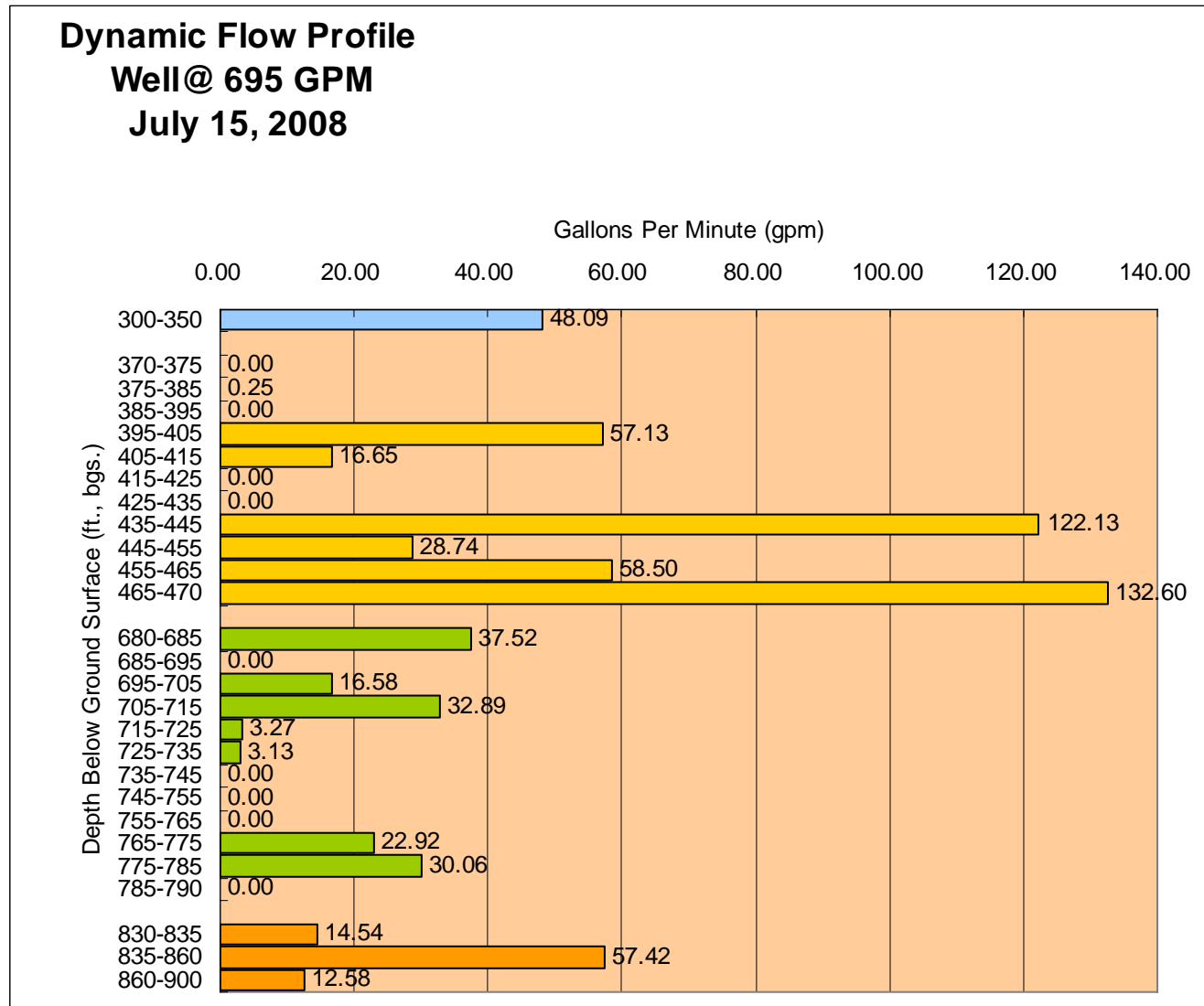
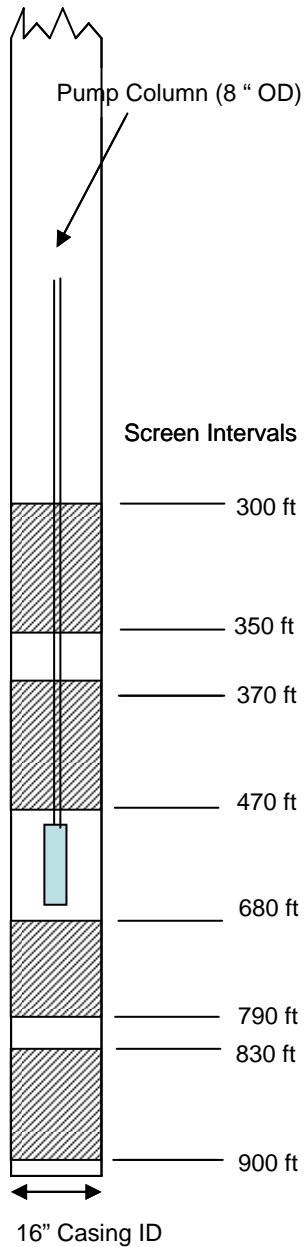

There are 4 screen intervals at Sample Well. The Top interval between 300'-350' produces approximately 48.09 gpm. This is about 6.9 % flow contribution. The next zone is the interval between 370'-470' which produces 416 gpm. This is about 59.9 % of the flow contribution in the well. The Screen Interval from 680'-790' produces 146 gpm, or 21.1%. The entire breakdown of flow contribution is displayed in the series of graphs in this report.

Dynamic Flow Contribution By Depth and Screen Intervals

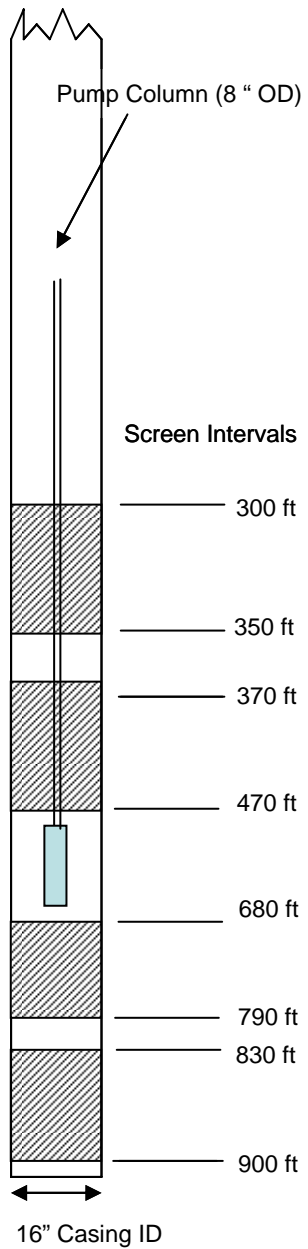

Dynamic Flow Profile
Well @ 695 GPM
July 15, 2008

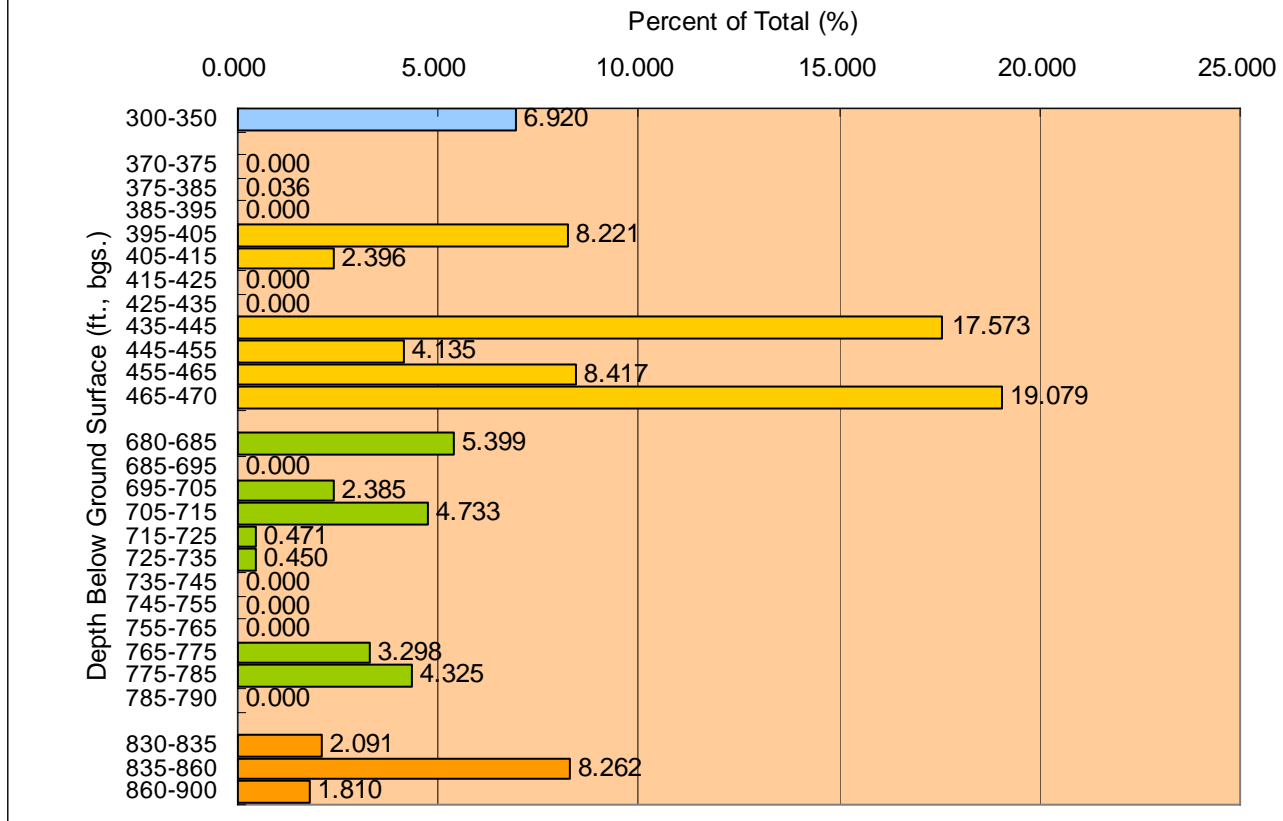

Dynamic Flow Velocity By Dye Injection Depth

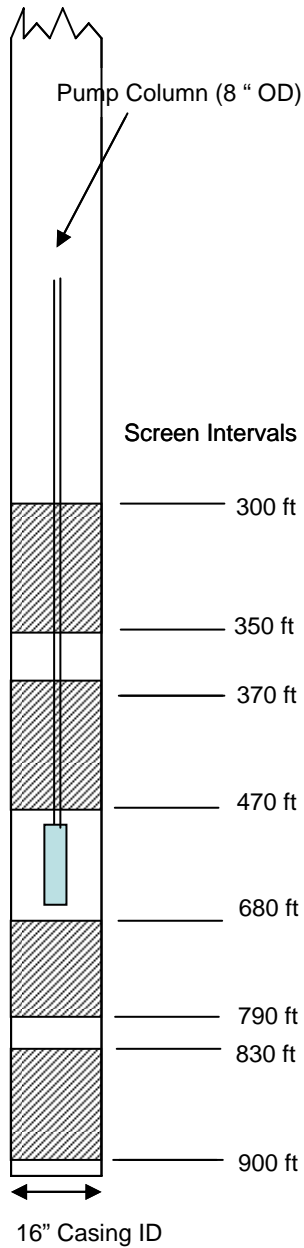

Dynamic Flow Velocity Well @ 695 GPM July 15, 2008

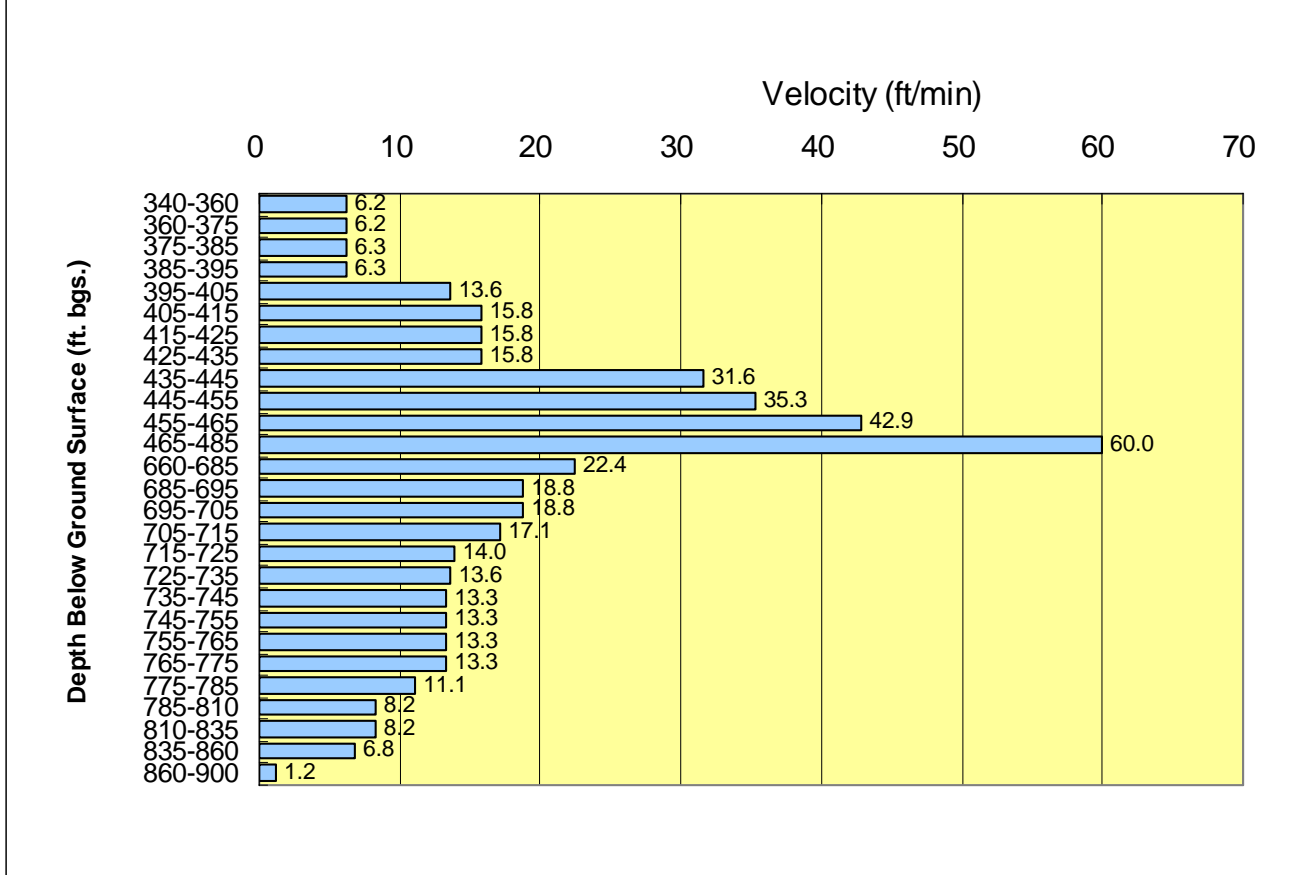

Note: The Well reached steady state pumping rate at 340' bgs.

Geologic Log and BESST Dynamic Flow Profile

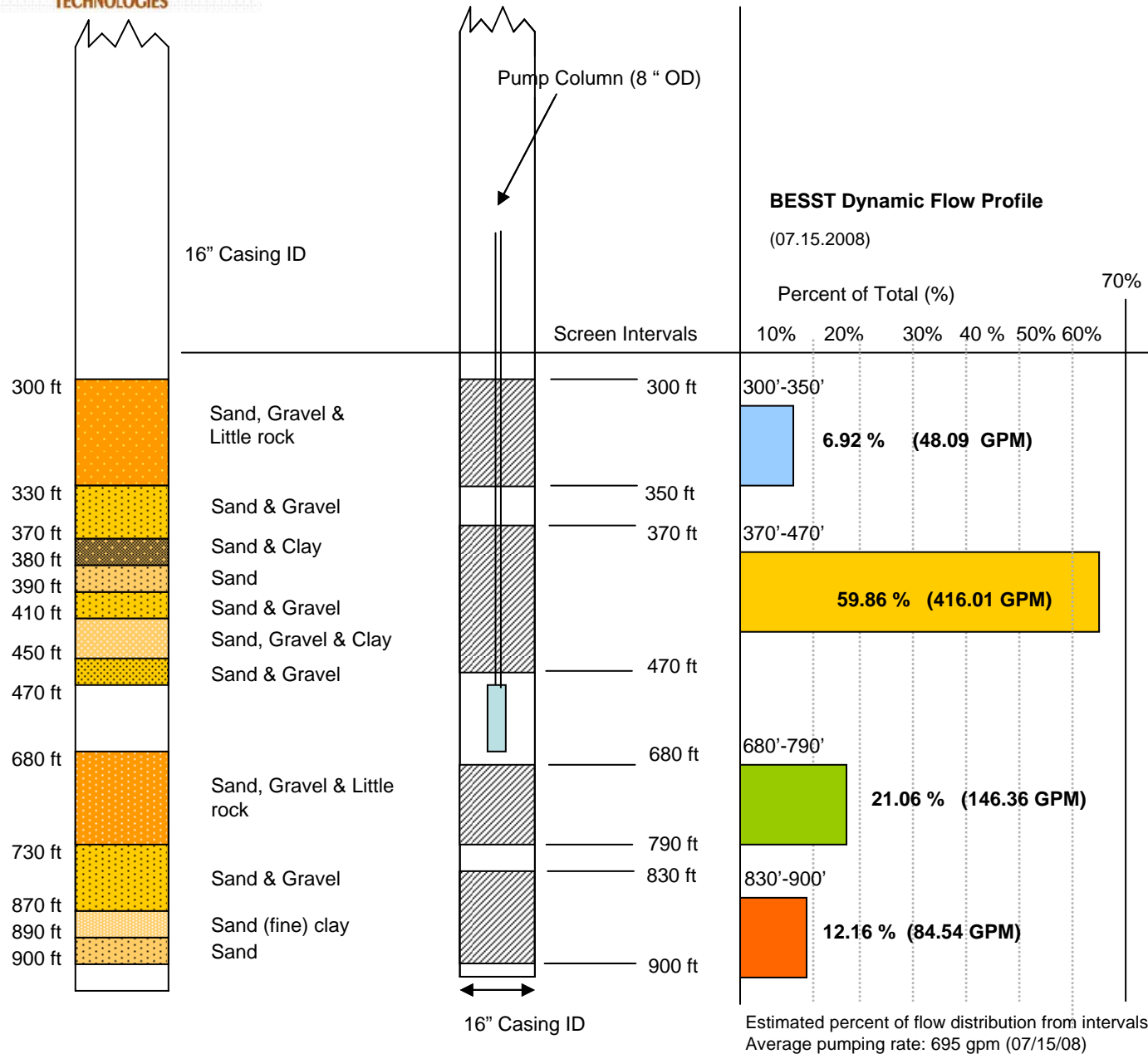

Mass Balance Analysis By Depth and Screen Intervals

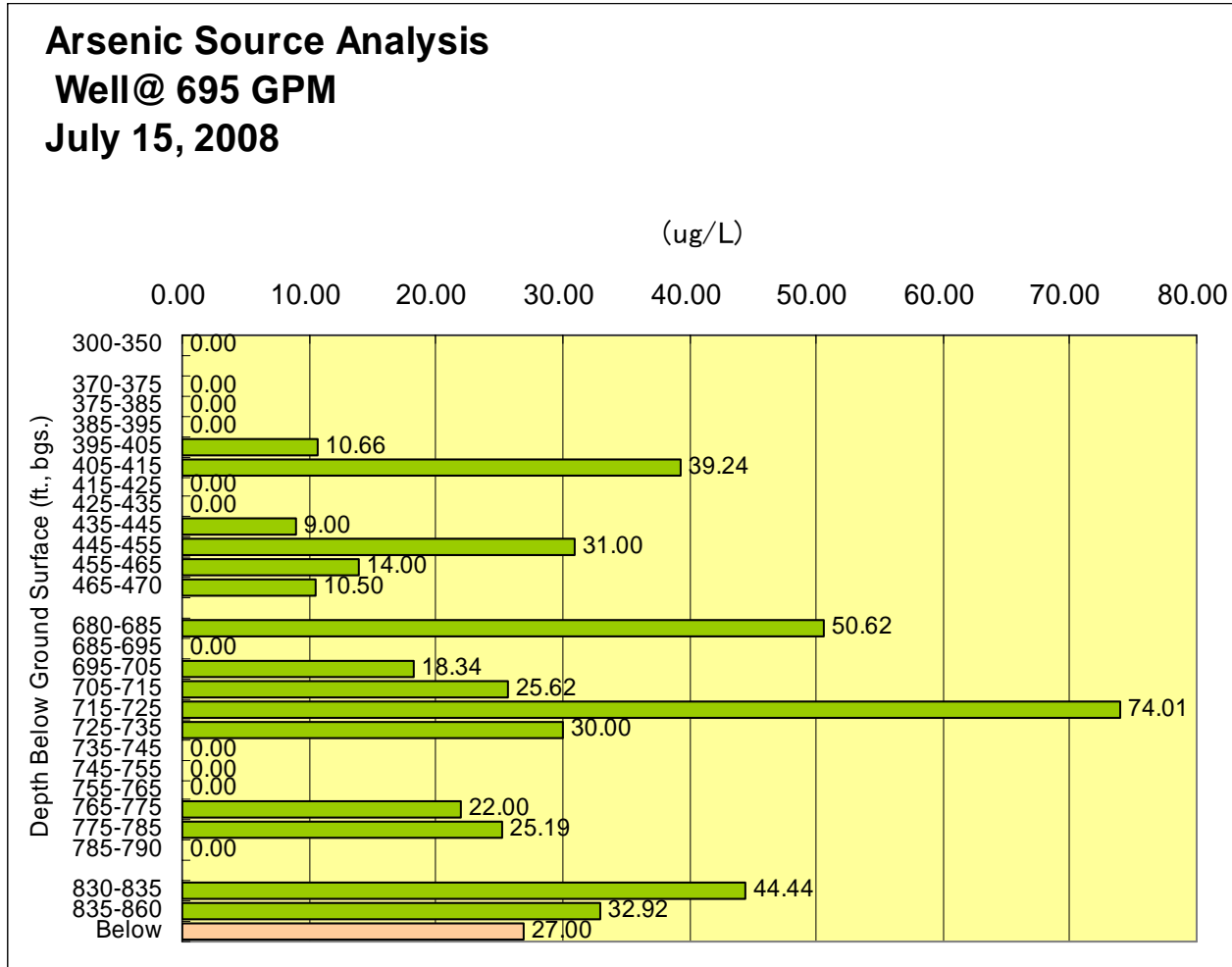
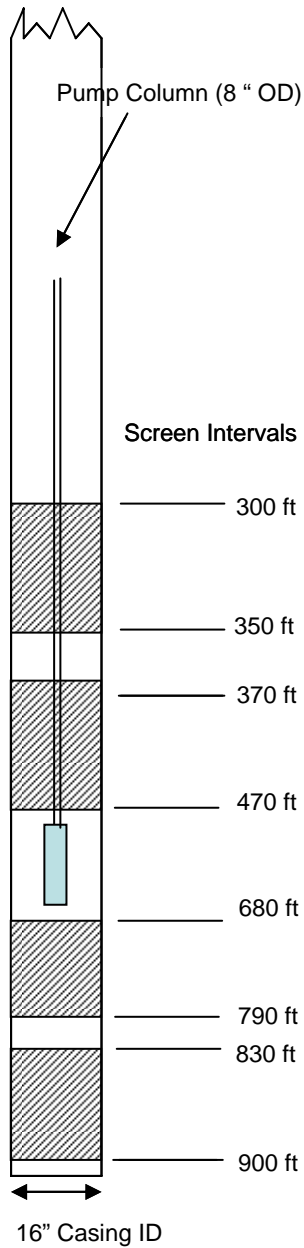

NOTE: No sampling results available below 860' bgs. In order to estimate concentration of Arsenic depth below 860', more data points are required.

Mass Balance Analysis By Depth and Screen Intervals

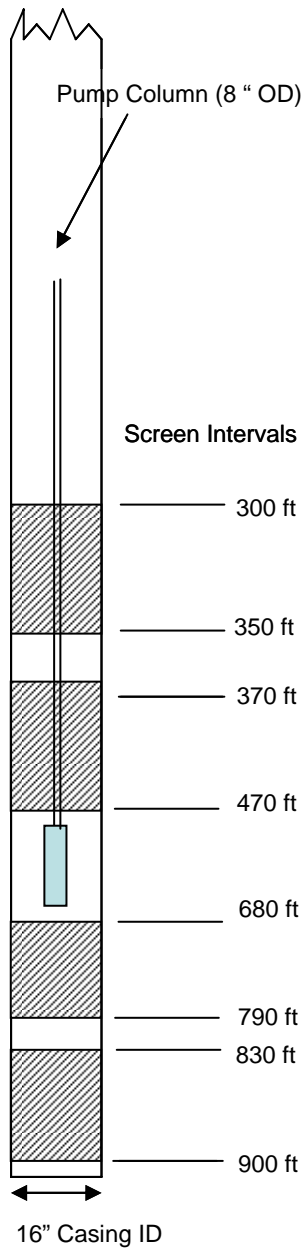

Iron Source Analysis Well @ 695 GPM July 15, 2008

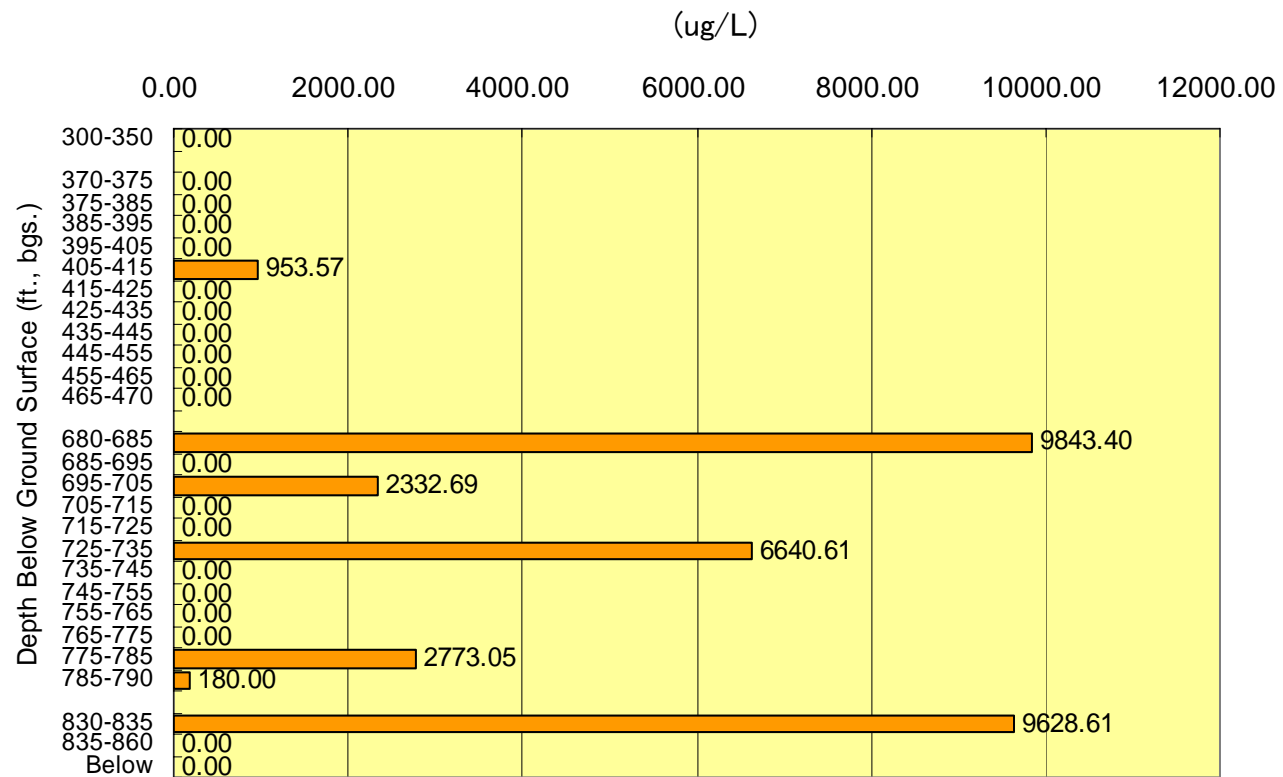

Mass Balance Analysis By Depth and Screen Intervals

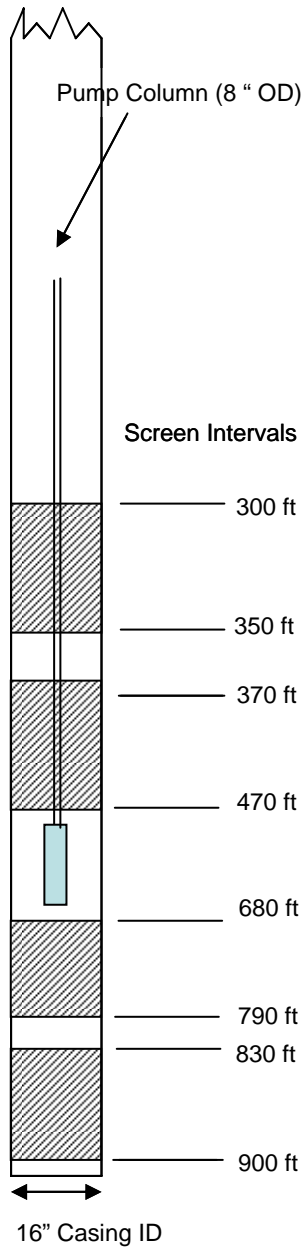

Copper Source Analysis Well @ 695 GPM July 15, 2008

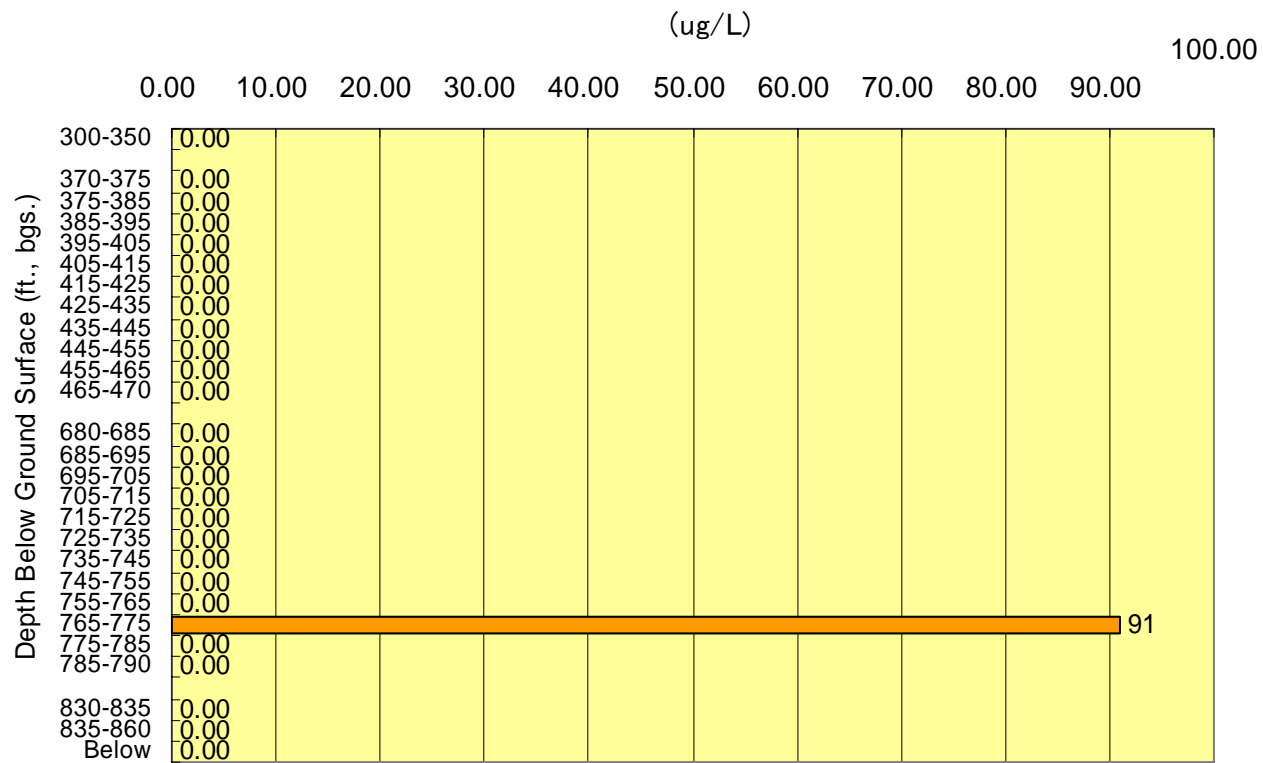

Well Information

Sample Well:

Pump Intake Depth (ft. bgs.)	506
Well Diameter (in)	16.0
Pump Column (in)	8.0
Cross Sectional Area of well (ft ²)	1.396
Measured Well Bottom (ft. bgs.)	920
Measured Discharge (gpm)	695
Pumping Water Level (ft)	340

